

Zamawianie

Unit	Stalówka Ø*	Pręt Ø**	Długość sztagu		Przetyczka Ø	Taśma w liku żagla		
			Standard	Maks.		#	in	mm
3	$7/16", 1/2"$	-22, 9.53 mm	75'6"	82'6"	$3/4"$ (19.10 mm)	6	$5/32$	5
	11, 12 mm	-30, 11.10 mm	23.01 m	25.15 m	$7/8"$ (22.20 mm)			
3.25	$9/16"$	-40, 12.70 mm	75'6"	89'6"	$7/8"$ (22.20 mm)	6	$5/32$	5
	14 mm		23.01 m	27.28 m	1" (25.40 mm)			
3.5	$5/8", 3/4"$	-48, 14.30 mm	77'4"	95'4"	$7/8"$ (22.20 mm)	6	$5/32$	5
	16, 19 mm		23.57 m	29.06 m	1" (25.40 mm), $1\ 1/8"$ (28.60 mm)			
4	$7/8"$	-60, 16.80 mm	87'11"	114'11"	$1\ 1/4"$ (31.80 mm)	6	$5/32$	5
	22 mm	-76, 17.90 mm	26.80 m	35.03 m				
4.5	1"	-76, 17.90 mm	102'7"	126'7"	$1\ 1/4"$ (31.80 mm)	6	$5/32$	5
	25 mm	-91, 19.50 mm, -115, 22.20 mm	31.27 m	38.58 m	$1\ 1/8"$ (34.90 mm), $1\ 9/16"$ (39.70 mm)			

*Rozmiary nie dotyczą stalówek Dyform® **Jeśli pręt inny niż Nitronic® 50 skontaktuj się z firmą Harken®. Wersje z włókna węglowego pracują tylko z prętami

†Tylko dla prętów jednoelementowych. Jeśli pręt jest podzielony na sekcje, zamów wersję 4.5

Wymiary Rolera

Unit	A	B	C	D	E	F	G	H	I	J
3	$34\ 1/2"$	$24\ 1/8"$	$20\ 5/8"$	$9\ 1/2"$	$10\ 3/4"$	12"	$7\ 1/4"$	$7\ 5/8"$	$7\ 3/4"$	12"
	876 mm	613 mm	524 mm	241 mm	273 mm	305 mm	184 mm	200 mm	197 mm	305 mm
3.25	35"	$24\ 5/8"$	$21\ 1/8"$	10"	$11\ 1/4"$	$12\ 1/2"$	$7\ 3/4"$	$7\ 5/8"$	$7\ 3/4"$	12"
	889 mm	625 mm	537 mm	254 mm	286 mm	318 mm	197 mm	200 mm	197 mm	305 mm
3.5	$37\ 3/4"$	25"	$21\ 1/2"$	$10\ 5/8"$	$11\ 5/8"$	$12\ 7/8"$	$7\ 5/8"$	$7\ 11/16"$	$9\ 1/16"$	$13\ 3/16"$
	959 mm	635 mm	546 mm	264 mm	295 mm	327 mm	194 mm	195 mm	233 mm	335 mm
4	$47\ 1/4"$	$31\ 3/8"$	$27\ 1/4"$	14"	15"	17"	$8\ 1/2"$	$9\ 5/8"$	$10\ 5/8"$	$15\ 1/4"$
	1200 mm	797 mm	692 mm	357 mm	381 mm	432 mm	216 mm	244 mm	270 mm	387 mm
4.5	$48\ 5/8"$	$32\ 1/2"$	$28\ 1/4"$	$14\ 5/8"$	$15\ 7/8"$	$17\ 7/8"$	$8\ 1/2"$	$9\ 5/8"$	14"	$18\ 1/8"$
	1235 mm	826 mm	718 mm	378 mm	403 mm	454 mm	216 mm	244 mm	356 mm	460 mm

Wymiary Profili

Unit	K	L	Długość profili	Taśma w liku żagla
3	$1\ 1/4"$	$1\ 11/16"$	7'	#6
	33 mm	43 mm	2.13 m	$5/32"$ (5 mm)
3.25	$1\ 1/4"$	$1\ 11/16"$	7'	#6
	33 mm	43 mm	2.13 m	$5/32"$ (5 mm)
3.5	$1\ 9/16"$	$1\ 15/16"$	9'	#6
	40 mm	49 mm	2.74 m	$5/32"$ (5 mm)
4	2"	$2\ 7/16"$	9'	#6
	50 mm	61 mm	2.74 m	$5/32"$ (5 mm)
4.5	$2\ 11/16"$	$3\ 3/16"$	12'	#6
	68 mm	81 mm	3.66 m	$5/32"$ (5 mm)

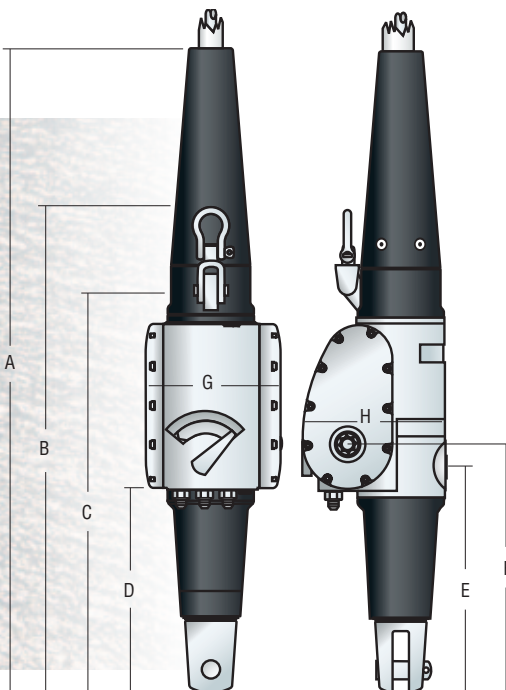
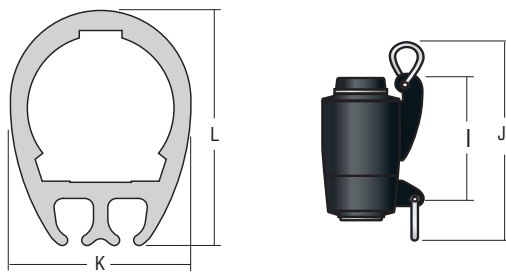

Gweilo, 47 m, Gerald Dykstra & Partners, Mengi-Yay — Kadir Kir (aerial), Captain Marcel van den Houtdt (deck) photos